



Non-Contact
Measuring Systems



Kestrel® provides the optical quality and measurement accuracy of a superior 2 axis non-contact measuring system, in a configuration which is also ideally suited to workshop/shop floor use by production engineers and quality assurance personnel

Kestrel® has been designed by engineers for engineers to reflect the following criteria

Kestrel® incorporates the latest patented Dynascope® image projection technology to give high contrast, high resolution images of complex parts in a wide variety of materials. Images are viewed through an ergonomic high resolution projection head



Kestrel® has been designed by engineers for engineers to reflect the following criteria

- Durable design
- Accurate and repeatable
- Ease of use
- Simplified data displays
- Data download and printing capabilities
- Flexible, user friendly digital readout
- Traceability and reporting features for ISO9000

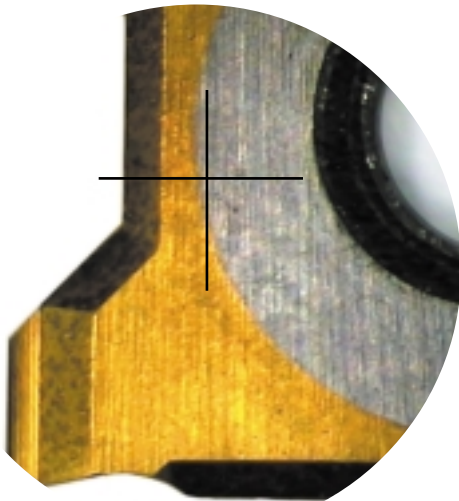

With over 40 years experience in the design and manufacture of measuring and inspection systems for manufacturing industry worldwide, Vision Engineering is proud of its reputation for excellence



Technical Specification



Optical

- Twin Pupil Monoscopic, infinity corrected optical system utilising patented Dynascopic® Exit Pupil Expansion Technology
- Precentered Crossline reticle to both eyes
- Custom designed reticle option, precentered, to one eye

Magnification

- 20X total magnification standard with quick change single high numerical aperture objective
- 10X : 50X high numerical aperture objective options

Illumination

Surface Reflected (Options)

- Semi coaxial 2 x 30Watt spotlamps with integral power supply (600 hours)
- Semi coaxial 150Watt 6 point ringlight with free-standing fibre optic illuminator and power supply (200 hours)
- Episcopic, through the lens 75Watt illumination (200 hours)

Substage Transmitted (Standard)

- Substage 30Watt illumination (600 hours)

Measurement

- Displacement measurement, high performance 3 plate aluminium stage. Gimbal mounted for Z axis levelling
- Measuring range:
 - 150mm (6") in X axis
 - 100mm (4") in Y axis
- 2 glass scale displacement encoders with 0.001mm (0.000039") resolution
- Angular resolution 1 second of arc
- Maximum Stage Load 10Kg (22lbs)

Optical Information

Objective Lens Part Number	Magnification	Working Distance	Field of View
K-007	10X	81mm (3.2")	14.2mm (0.6")
K-008	20X	81mm (3.2")	7.1mm (0.3")
K-009	50X	61mm (2.4")	2.9mm (0.12")

Accuracy Statements

System Accuracy	Better than 0.007mm
Stage Accuracy	0.001mm per 10mm
Stage Repeatability	0.004mm
(Calculation Max Deviation $X Y = \sqrt{(\max x^2) + (\max y^2)}$ at the maximum deviation point)	

Data Options

- QuadraChek microprocessor with:
 - Numerical & graphical display
 - Multilanguage
 - Parallel printer port
 - RS 232 port
 - Non linear error correction
 - Port programming
 - Skew/Datum
- QuadraChek PC based fully geometric software option (More details available)

Accessories

- Digital, Video, camera options via high resolution, full field adaptor
- Supplementary glare reduction hood for very bright environments

Weight

	Packed	Unpacked
Head	5kg	4kg
Focus Assy/Illumination	3.5kg	2.5kg
Stand/Stage	38.5kg	34kg
Microprocessor	7kg	6kg

Dimensions

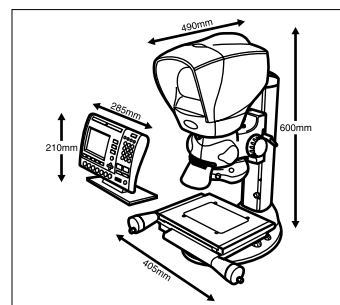

We serve industry and laboratories world wide, from major multinational corporations to small privately owned companies.

Each receives the same high standard of pre and post sales service, whether direct from one of Vision's subsidiaries or one of our highly trained and skilled distributors. With our products now represented in over 30 countries, Vision responds to customer demand with speed, efficiency and with innovative solutions.

Distributor



Around the world

Vision Engineering Ltd.
(Manufacturing)
Send Road, Send, Woking
Surrey, GU23 7ER
England
Tel: +44 (0) 1483 223417
Fax: +44 (0) 1483 223297



Vision Engineering Ltd.
(Commercial)
Monument House
Monument Way West
Woking, Surrey, GU21 5EN
England
Tel: +44 (0) 1483 248300
Fax: +44 (0) 1483 248317
E-Mail: generalinfo@visioneng.com
Website: www.visioneng.com



Vision Engineering Inc.
(Manufacturing & Commercial)
570 Danbury Road
New Milford
CT 06776
USA
Tel: +1 (860) 355 3776
Fax: +1 (860) 355 0712
E-Mail: info@visioneng.com
Website: www.visioneng.com



Vision Engineering Inc.
(Commercial)
745 West Taft Avenue
Orange
CA 92865
USA
Tel: +1 (714) 974 6966
Fax: +1 (714) 974 7266



Vision Engineering Ltd.
(Central Europe)
Anton Pendele Strasse 3
D-82275, Emmering
Germany
Tel: +49 (0) 8141 40167-0
Fax: +49 (0) 8141 40167-55
E-Mail: info@visioneng.de
Website: www.visioneng.de



Nippon Vision Engineering
No. 6 Shinyokohama Hayama Building
1-28-8 Shinyokohama
Kohoku-ku, Yokohama-shi
Japan
Tel: +81 (0) 45 472 1004
Fax: +81 (0) 45 472 1177
E-Mail: info@visioneng.jp
Website: www.visioneng.jp



Vision Engineering Ltd.
1 Rue de Terre Neuve
ZA Courtaboeuf
91967 Les Ulis Cedex
France
Tel: +33 (0) 164 46 90 82
Fax: +33 (0) 164 46 31 54
E-Mail: info@visioneng.fr
Website: www.visioneng.fr

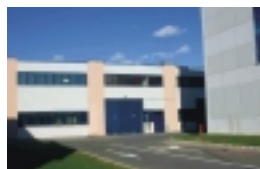

Vision Engineering Ltd Italia
Via Pelizza da Volpedo 51
20092 Cinisella Balsamo MI
Italy
Tel: +39 02 6129 3518
Fax: +39 02 6129 3526
E-Mail: info@visioneng.it
Website: www.visioneng.it

Visit our Interactive Multilingual Website
www.visioneng.com